

# Parade Recessed

L1 - L2 - L3 - L4

## User Manual

551092 Rev.11

Date: 19/03/2026



	Parade L1 Recessed	Parade L2 Recessed	Parade L3 Recessed	Parade L4 Recessed
Code / Codice	AL5063	AL5068	AL5073	AL5078
Power consumption Consumo di energia	20W (RN) 19W (DW) 19W (W)	38W (RN) 38W (DW) 37W (W)	58W (RN) 57W (DW) 56W (W)	79W (RN) 76W (DW) 75W (W)
Nominal current Corrente nominale	0.1A (RN) 0.1A (DW) 0.1A (W) @230Vac	0.17A (RN) 0.17A (DW) 0.17A (W) @230Vac	0.26A (RN) 0.26A (DW) 0.25A (W) @230Vac	0.35A (RN) 0.34A (DW) 0.34A (W) @230Vac
Power supply Alimentazione elettrica	220-240VAC 50-60Hz (CE version)			
Inrush current / Corrente di spunto	23.4 A @240VAC, 25°C		27.5 A @ 240VAC, 25°C	
Power factor / Fattore di potenza	cos.φ=0.87	cos.φ=0.95	cos.φ=0.97	cos.φ=0.97
Electrical class / Classe elettrica	I			
Weight / Peso	4.3 Kg ( 9,5 Lb )	6.6 Kg ( 14,5 Lb )	9.2 Kg ( 20,3 Lb )	13 Kg ( 28,7 Lb )
Operating temperature Temperatura di funzionamento	-40°C to +50°C ( -40°F to 122°F )			
IP rating / Grado IP	IP67			
IK rating / Grado IK	IK10			

## Dimensions / Dimensioni

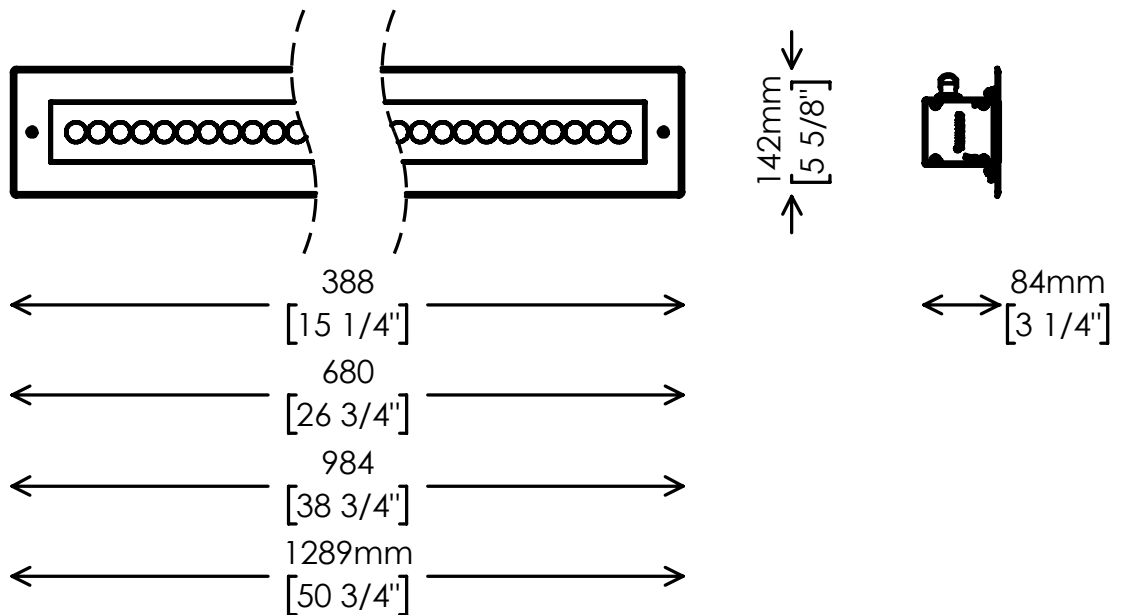

## Important notices - Avvisi importanti

- This product must be installed in accordance with applicable national and local electrical and construction codes by a person familiar with the construction and operation of the product and the hazards involved. Failure to comply with the following installation instructions may result in death or serious injury.

Questo prodotto deve essere installato secondo le normative locali, da personale specializzato. La mancata osservanza delle istruzioni di installazione può portare a situazioni di pericolo all'incolumità della persone.

- The fixture might be damaged by excess voltage. The installation of an overvoltage protection device on the electrical system may reduce the risk of damage.

Apparecchiatura sensibile alle sovratensioni. L'installazione di un dispositivo di protezione delle sovratensioni sull'impianto elettrico attenua l'intensità di questi fenomeni proteggendo gli apparecchi dal rischio che vengano danneggiati.

- The use of an adequate magnetothermic switch along the power supply line is recommended.

E' consigliato l'uso di un adeguato interruttore magnetotermico/differenziale sulla linea di alimentazione.

- Connect the fixtures to each other only when disconnected from mains.

Collegare tra loro i proiettori solo quando nessuno di essi è collegato alla rete elettrica.

- Never leave cables and connectors unconnected or unprotected for long periods.

Non lasciare mai per lungo tempo agli agenti atmosferici cavi e connettori non collegati o non protetti.

- Disconnect power before installing or servicing to avoid electrical shock.

Togliere l'alimentazione prima di effettuare qualsiasi operazione all'interno dell'apparecchiatura.

- Disconnect power before any connection operation.

Togliere l'alimentazione prima di effettuare qualsiasi operazione di connessione tra gli apparecchi.

- Check voltage and frequency before powering the fixture. Do not exceed fixture specified voltage.

Prima di connettere l'apparecchio alla rete elettrica, verificate la compatibilità di tensione e frequenza.

- Do not handle the unit with wet hands or in wet environments.

Non maneggiare il prodotto con mani bagnate o in presenza di acqua.

- Apply to qualified staff for any maintenance service not described in this instructions manual.

Rivolgersi ad un tecnico qualificato per qualsiasi operazione di manutenzione ordinaria non descritta nel presente manuale.

- Do not exceed the maximum quantity of fixtures per line in order to avoid power surges.

Non superare il numero massimo specificato di apparecchi per linea per evitare pericoli di sovraccarichi di corrente.

- Before powering the unit, ensure to use cables and connectors with proper section and length, according to its power consumption.



Prima di effettuare le connessioni verificare la portata dei cavi / connettori e la lunghezza dei cavi tenendo conto dell'assorbimento del prodotto.

- Fix the projector by using screws, hooks or other adequate supports that can bear its weight.

Fissare il proiettore con viti, ganci o altri supporti in grado di sostenerne il peso.



- All devices connected to the DALI bus must be SELV type.

Tutte le apparecchiature connesse al bus DALI devono essere di tipo SELV.

  **CAUTION! The luminaire should be positioned so that prolonged staring into the luminaire at a distance closer than 11(36ft) meters is not expected.**

  **ATTENZIONE! L'apparecchio deve essere posizionato in modo che non si possa fissarlo a lungo a una distanza inferiore a 11 metri.**

  **WARNING! Fixing and connecting operations must mandatorily be carried out by qualified personnel!**

  **ATTENZIONE! Le operazioni di fissaggio e collegamento devono essere eseguite solo e obbligatoriamente da personale qualificato!**

  **WARNING! Make sure that power supply is off before connecting or disconnecting fixtures!**

  **ATTENZIONE! Assicurarsi che l'alimentazione sia spenta prima di collegare o scollegare i dispositivi!**



The possibility of reusing some electrical parts of the device is subject to the total responsibility of the user. The label shows the symbol indicated in Legislative Decree n.49 of 14 March 2014 which transposes Directive 2012/19 / EU, which indicates the need to dispose of the product in separate waste, specifically in electrical waste. and electronic. Refer to the waste collection center located in your area.



La possibilità di riutilizzare alcune parti elettriche del dispositivo è subordinata alla totale responsabilità dell'utilizzatore. Nell'etichetta è stato riportato il simbolo indicato nel D.lgs n.49 del 14 Marzo 2014 che recepisce la direttiva 2012/19/UE, il quale indica la necessità di smaltire il prodotto nei rifiuti differenziati, nello specifico nei rifiuti di tipo elettrico ed elettronico. Fare riferimento al centro di raccolta rifiuti situato nella Vostra zona.



**Replaceable control gear by a professional**



**Alimentatore sostituibile da un professionista**



**The light source contained in this luminaire shall only be replaced by the manufacturer or his service agent or a similar qualified person.**



**La sostituzione della sorgente luminosa contenuta in questa lampada deve essere effettuata solo dal produttore o dal suo agente di assistenza o da una persona qualificata.**

This product contains a light source of energy efficiency class:

Questo prodotto contiene una sorgente luminosa di classe di efficienza energetica:

3000K	4000K	Dynamic White	RGBW 4000K
F	F	E	F

## Connection - Connessione

“C” Cable type ( Hybrid cable + connectors )

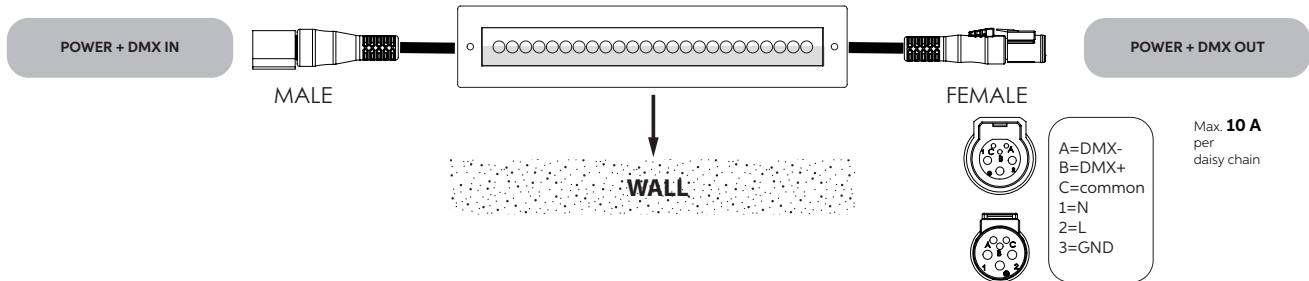

“M” Cable type ( Hybrid cable without connectors )

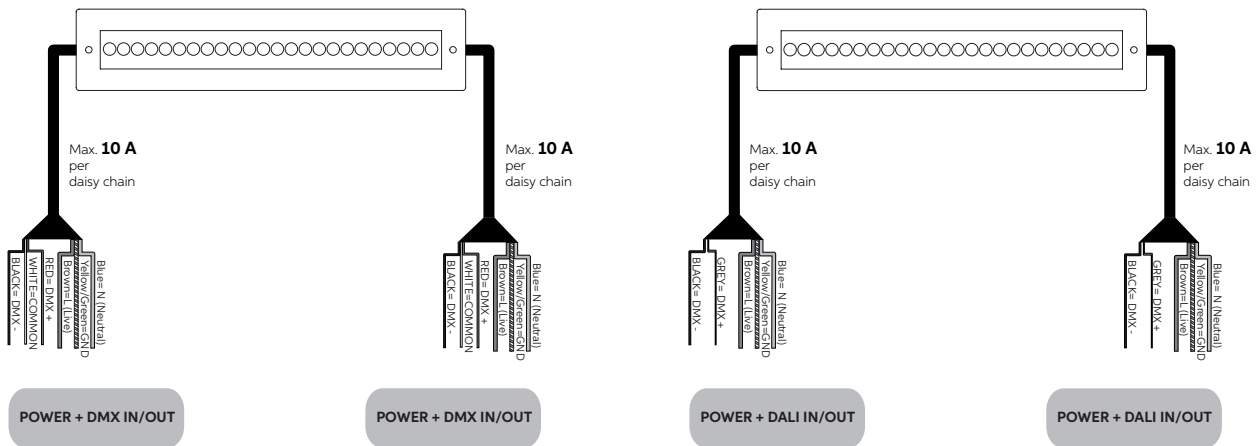

“M” Cable type ( Hybrid cable without connectors - Self Addressing version )

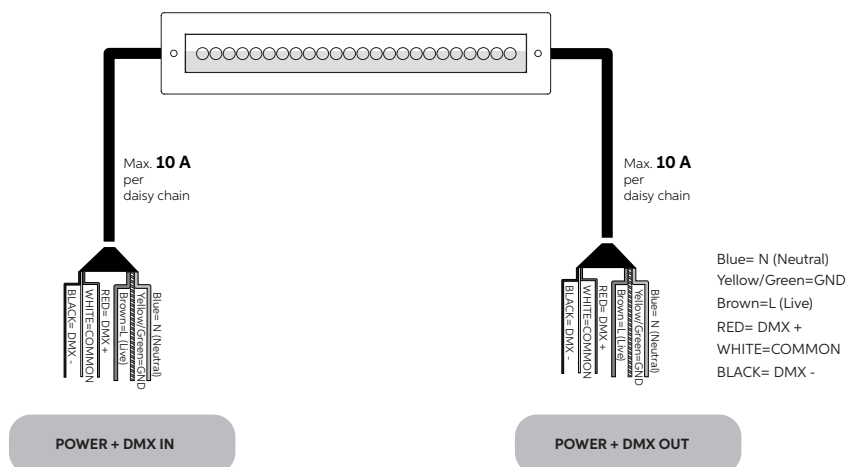

### ATTENZIONE - WARNING

ITA: I collegamenti dei cavi di tipo “S” ed “M” devono essere effettuati utilizzando il kit di collegamento **da ordinare separatamente**. Seguire le istruzioni fornite insieme al kit di connessione.

EN: The connections of the cables type “S” and “M” must be made using the connection kit **to be ordered separately**. Follow the instructions provided with the connection kit.

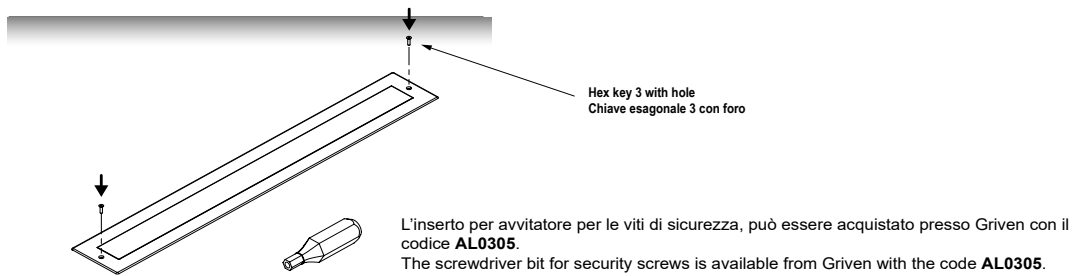
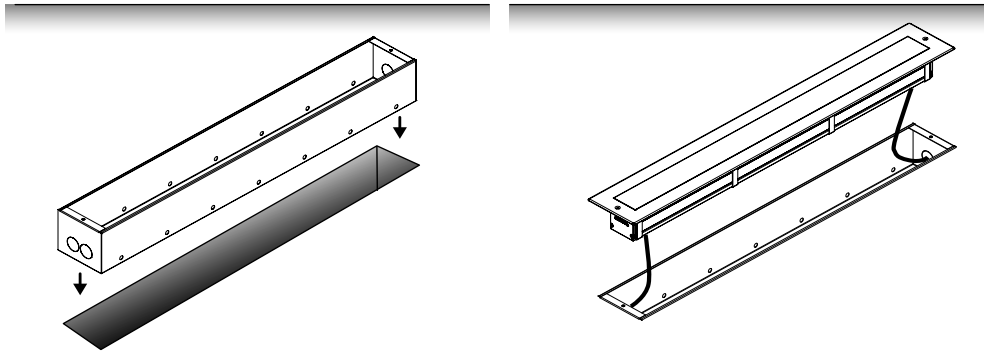
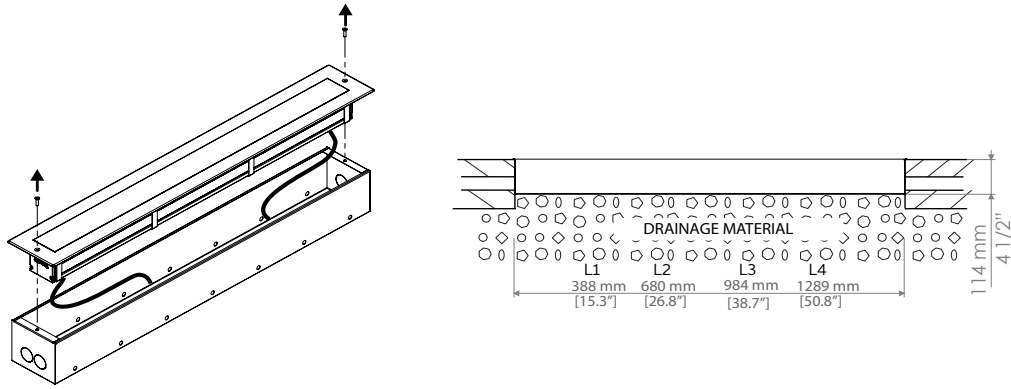

Polar features (only on Polar Edition fixtures )

Caratteristiche Polar (solo su dispositivi Polar Edition)

The POLAR Edition is fitted with a frontal thermal glass which is particularly useful for outdoor applications. In fact, by warming up, the glass melts ice and snow which might interfere with the projection. When the projector is on, if required by the weather conditions, the glass automatically warms up.

La POLAR Edition è dotata di un vetro termico frontale particolarmente utile per applicazioni outdoor. Infatti, riscaldandosi, il vetro scioglie il ghiaccio e la neve che potrebbero interferire con la proiezione. Quando il proiettore è acceso, se richiesto dalle condizioni meteorologiche, il vetro si riscalda automaticamente.

**WARNING: If the projection is to be started at a definite time, deice the glass in advance, so that when the LEDs are switched on at the definite time the glass will be clean.**

**ATTENZIONE: Se la proiezione deve essere avviata ad una determinata ora, sghiacciare in anticipo il vetro, in modo che quando i LED vengono accesi all'ora stabilita, il vetro sia pulito.**

**WARNING: At very low temperatures (below -20° C), it is mandatory to leave the fixture always powered and to switch on the LEDs when needed.**

**ATTENZIONE: A temperature molto basse (inferiori a -20 ° C), è obbligatorio lasciare sempre l'apparecchio alimentato e accendere i led quando necessario.**

**Fixture configuration**

The equipment can be configured using the IR remote control AL1321 (sold separately) or via any DMX-RDM compatible controller.

**Configurazione dell'apparecchio**

L'apparecchiatura può essere configurata utilizzando il telecomando IR AL1321 (venduto separatamente) o tramite qualsiasi controller compatibile DMX-RDM.

# DMX Chart

## RGBW

Mode	Channel	Function	Value	
#1 IR=4	1	0-100% Red	0-255	
	2	0-100% Green	0-255	
	3	0-100% Blue	0-255	
	4	0-100% White	0-255	
#2 IR=5	1	0-100% Red	0-255	
	2	0-100% Green	0-255	
	3	0-100% Blue	0-255	
	4	0-100% White	0-255	
	5	0→100% Dimmer	0-255	
#3 IR=6	1	0-100% Red	0-255	
	2	0-100% Green	0-255	
	3	0-100% Blue	0-255	
	4	0-100% White	0-255	
	5	0% Dimmer	0-5	
		100-0% Dimmer	6-250	
		100% Dimmer	251-255	
	6	No Strobe	0-5	
		0-100% Strobe	6-250	
		100% Strobe	251-255	
	#4 IR=7	1	0-100% Red	0-255
2		0-100% Green	0-255	
3		0-100% Blue	0-255	
4		0-100% White	0-255	
5		NO FUNCTION	0-5	
		2700K	6-7	
		2700K→3000K	8-40	
		3000K	41-42	
		3000K→3500K	43-75	
		3500K	76-77	
		3500K→4000K	78-110	
		4000K	111-112	
		4000K→4500K	113-145	
		4500K	146-147	
		4500K→5000K	148-179	
		5000K	180-181	
		5000K→5500K	182-214	
		5500K	215-216	
		5500K→6000K	217-249	
6000K		250-255		
6		0→100% Dimmer	0-255	
#5 IR=8		1	0-100% Red	0-255
		2	0-100% Red	0-255
		3	0-100% Green	0-255
		4	0-100% Green	0-255
		5	0-100% Blue	0-255
		6	0-100% Blue	0-255
	7	0-100% White	0-255	
	8	0-100% White	0-255	

Mode	Channel	Function	Value
#6 IR=9 (Default)	1	0-100% Red	0-255
	2	0-100% Green	0-255
	3	0-100% Blue	0-255
	4	0-100% Calibrated White ( Affects RGB channels )	0-255

Note: in absence of DMX signal the LEDs will remain **OFF**.

## DW (Dynamic White)

Mode	Channel	Function	Value
#1 IR=2 (Default)	1	0%→100% Warm white	0-255
	2	0%→100% Cold White	0-255
#2 IR=3	1	0%→100% Warm white	0-255
	2	0%→100% Cold white	0-255
	3	0%→100% dimmer	0-255
#3 IR=3	1	0%→100% Warm white	0-255
	2	0%→100% Warm white fine	0-255
	3	0%→100% Cold white	0-255
	4	0%→100% Cold White fine	0-255

Note: in absence of DMX signal the LEDs will remain **ON**.

## Monochromatic version

Channel	Function	Value
1	0%→100% dimmer	0-255

Note: in absence of DMX signal the LEDs will remain **ON**.

### Independent pixels

Nelle versioni "Independent pixels" le funzioni citate nelle precedenti tabelle vengono ripetute per il numero di moduli dell'apparecchio. Es. Parade L3 RGBW nella modalità #1 impegna 12 canali. In the "Independent pixels" versions, the functions mentioned in the previous tables are repeated for the number of modules in the device. E.g. Parade L3 RGBW in mode #1 engages 12 channels.

### RDM functions

When operating in DMX mode the fixture can accept the following RDM commands:

- Discovery: Upon request of the RDM controller, the fixture signals its own presence (the RDM controller will display the fixture on a list).
- DMX address reading and setting.
- Channels number reading and setting.
- On / Off identification: This command is used to identify the fixture you want to get access to (the identification happens by switching on all the LEDs at full intensity).
- Manufacturer: it displays the name of the manufacturer (Griven).
- Model description: it displays the fixture's model.
- Software version description: it displays the current version of the firmware.
- Temperature: it displays the LEDs operating temperature value.

DALI supported commands

Command #	Description
1	Off
2	Up (Fade rate)
3	Down (Fade rate)
4	Step Up ( Increment arc power level )
5	Step Down ( Decrement arc power level )
6	Recall MAX level
7	Recall MIN level
8	Step down and off ( Decrement arc power level if at min level turn down )
16...31	Go to scene 0...15
32	Reset ( DALI factory default parameters )
33	Store actual level in the DTR
42	Store DTR as MAX level
43	Store DTR as MIN level
45	Store DTR as Power On level
46	Store DTR as Fade Time
47	Store DTR as Fade Rate
64-79	Store DTR as Scene 0...15
80-95	Remove from Scene 0...15
96...111	Add to Group 0...15
112...127	Remove from Group 0...15
128	Store DTR as Short Address
144	Query Status
145	Query Ballast
151	Query Version Number
152	Query Content DTR
153	Query Device Type
154	Query Physical Minimum Level
155	Query Power Failure
160	Query Actual Level
161	Query Max level
162	Query Min level
163	Query Power On level
164	Query System Failure level
165	Query Fade Time/Fade Rate
176...191	Query Scene level
192	Query Groups 0...7
193	Query Groups 8...15
194	Query Random Address High
195	Query Random Address Middle
196	Query Random Address Low

DALI version: 1, Device Type: 6(LED), Physical Min Level: 1 (0.1%)

# Configuration examples / Esempi di configurazioni

## Single Chain Configuration

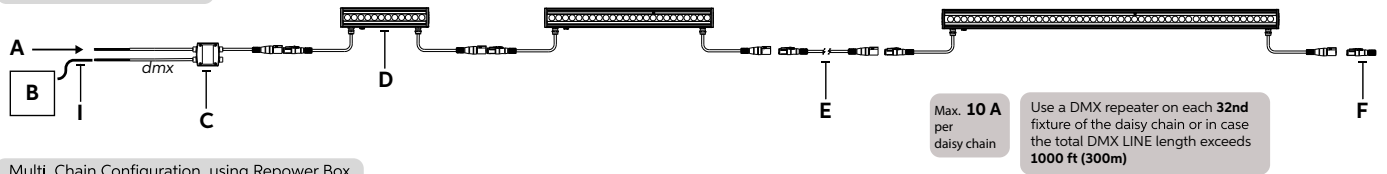

## Multi Chain Configuration using Repower Box

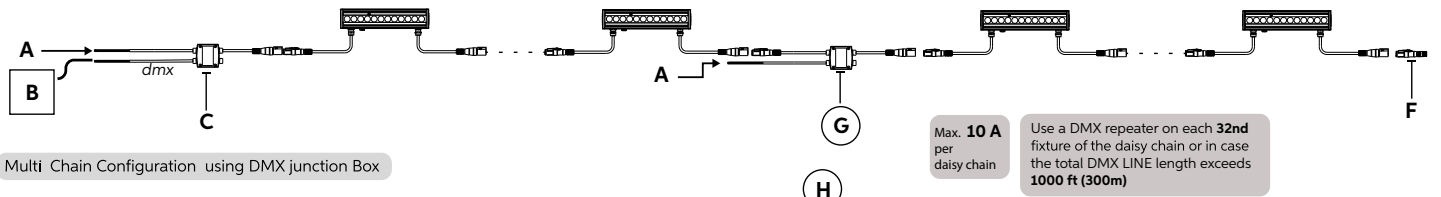

## Multi Chain Configuration using DMX junction Box

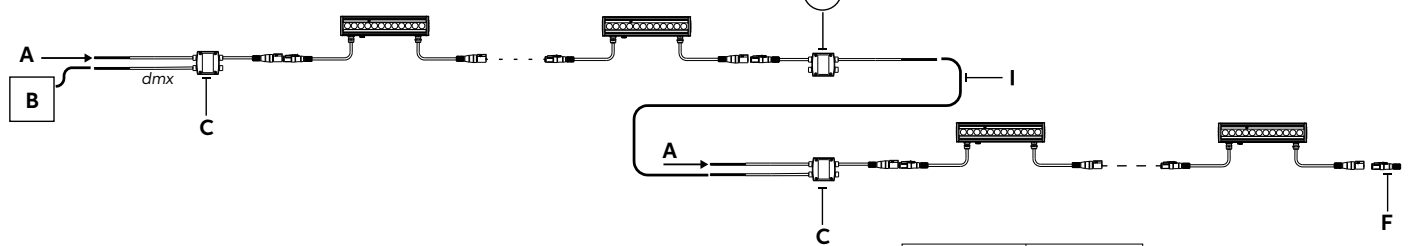

- A - Power Input
- B - DMX/RDM Controller
- C - Start Line Box - AL5058C with connectors / AL5058M without connectors
- D - Parade L-1, L-2, L-3, L-4, L-2 Recessed, L-3 Recessed
- E - Connection Cable - AL8264 L=1m AL8265 L=2m AL8266 L=3m AL8267 L=5m AL8268 L=10m
- F - DMX Terminator - AL5169
- G - Repower Box - AL5167C with connectos / AL5167M without connectors
- H - DMX Junction Box - AL5059C with connectors / AL5059M without connectors
- I - DMX Cable - AL0512

CE Colours	USE
Brown	Live
Blue	Neutral
Yellow/Green	Ground
Red	DMX Data +
Black	DMX Data -
White	DMX GND

# Operating modes / Modalità operative

## DMX Mode

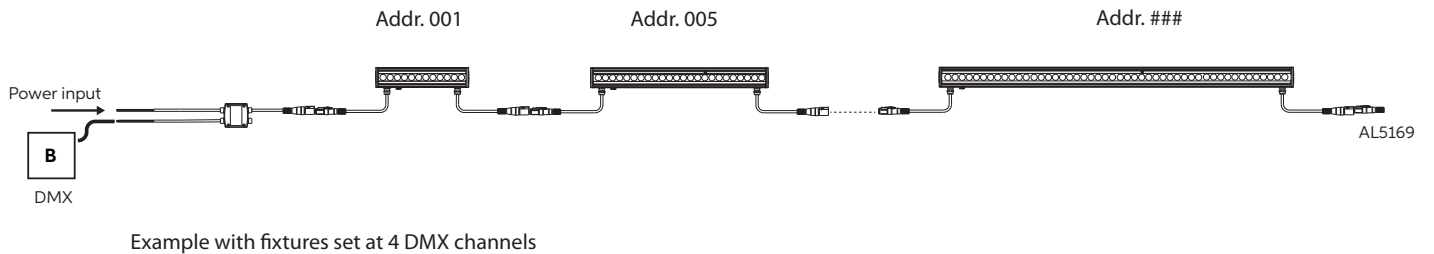

## Master-Slave / Automatic / Fixed color Mode

( Only DMX Mode #1 )

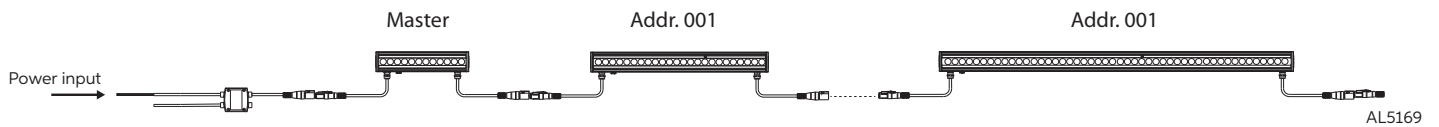

**WARNING !** in this mode, no DMX control device must be present along the line.  
**ATTENZIONE !** in questa modalità non deve essere presente lungo la linea nessun altro dispositivo di controllo DMX.

### NOTE

Maintenance of the declared insulation barrier for the luminarie can also be dependent on other external components / products connected to the same control bus. This is the responsibility of the control system designer, not the luminarie manufacturer.

Il mantenimento del grado di isolamento dichiarata per il prodotto può dipendere anche da altri componenti/prodotti esterni collegati allo stesso bus di controllo. La responsabilità è del progettista del sistema di controllo, non del produttore della lampada.